

MCS

DYEING & FINISHING MACHINERY

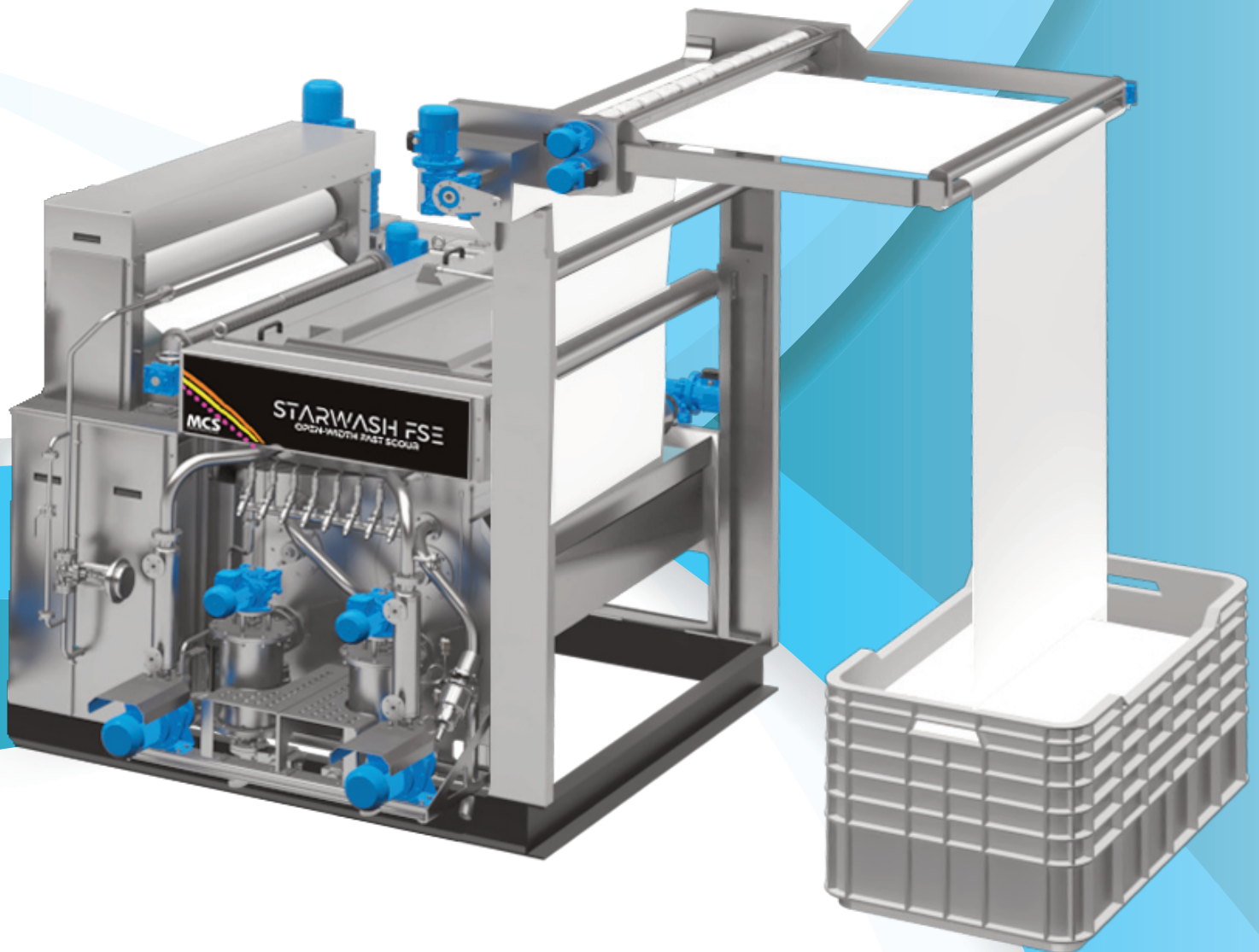

STARWASH FS EVO

OPEN-WIDTH TENSION-LESS SCOURING BOX



OUR HISTORY

DYEING & FINISHING MACHINERY

MCS

MCS & TERMO INNOVATION ZONE

BLUE
AREA

COMMISSION ECO-DYEHOUSE

EUROPIZZI

AUTOMATION & SOFTWARE

Termo
elettronica



mcsgroup.it
Bergamo - Italy

member of
ACIAIT
ITALIAN TEXTILE MACHINERY

MCS spa, since 1963, develops, manufactures and installs discontinuous dyeing machines and washing & preparation lines

2023 ITMA - Milan

MCS exhibits:

- Multiwash-M,
- Comby Jigger-C4,
- Chronoflow,
- Softflow-18

2019 ITMA - Barcellona

MCS exhibits:

- Lavaprint Next,
- Dynamica Sprint,
- Mini Jigger 98,

MCS presents:

- C4 Comby Jigger 143;
- Softflow 18-HT.

2017

MCS presents:

- Mini Jigger 98.

2015 ITMA - Milan

MCS exhibits:

- Multiwash,
- Dynamica Sprint,
- Starwash FS,
- Termopowder XP,
- Texmanager XP,
- Termochem XP.

2014 ITMA - Shanghai

MCS exhibits:

- Starwash Fast Scouring.

2013

MCS celebrate their 50 th anniversary

2011 ITMA - Barcellona

MCS exhibits:

- Dynamica,
- Star Wash,
- Comby Jigger,
- Supervisor Texmanager.

2009

MCS presents:

- Italica.

2008

MCS Re-design of all high and low temperature Jigger models.

2007 ITMA - Munich

MCS exhibits:

- Universal Dyeing,
- First Vento,
- Tumbler Mistral,
- VDA.

2005 IKME - Milan

MCS exhibits:

- Universal Dyeng, VDA.

2003 ITMA - Birmingham

MCS exhibits:

- Multiflow Superior,
- Ecoturbo Beam Dyeing Machine.

2000

MCS acquires 100% of Termoelettronica owner-ship.

1999 ITMA - Paris

MCS exhibits:

- Multiflow,
- Softflow 100 Evolution,
- Comby jigger electronic.

1995 ITMA - Milan

MCS exhibits:

- Softflow,
- Long Horn,
- Pumex

1991 ITMA - Hannover

MCS exhibits:

- Tornado Tumbler,
- Maxi & Mid jiggers,
- Lavaprint.

1987 ITMA - Paris

MCS exhibits: Pandora.

1983 ITMA - Milan

MCS exhibits:

- Tubular mercerizer MT26,
- Softflow-82 LT/HT,
- Flow/jet OF83,
- Comby Jigger HT,
- WR rope washing machine.

1980

Europea activity begins, group dyeing and resining company.

1979 ITMA - Hannover

MCS exhibits:

- Jet HT,
- Overflow MO/80 LT,
- MRS65.

1974

MCS begins the design and development of the open width lines.

1971 ITMA - Paris

MCS exhibits:

MCS exhibits the first low temperature jet model.

1968

Europizzi begins its activity

1967

MCS manufactures the first low temperature rope dyeing machine.

1964

MCS begins its activity.

1963

Gino Chiappini, Angelo Cagnazzo, founding MCS. Gino Chiappini is the Chairman of the Board.



STARWASH FS EVO

OPEN-WIDTH TENSION-LESS BOX SCOURING

STARWASH FS EVO (Escovagem rápida) foi concebida para a limpeza em contínuo por fixação térmica, a fim de reduzir a quantidade de óleo presente nos tecidos elásticos e melhor prepará-los para as posteriores fases de laboração.

Os óleos a eliminar são principalmente os silicões provenientes dos elastómeros e os minerais utilizados como lubrificantes em tecelagem. Estes óleos, queimando com as altas temperaturas da fixação térmica, são eliminados de forma não uniforme e criam zonas de absorção variada no interior do tecido.

Reduzir e uniformizar estes óleos sobre a superfície do tecido torna-se então uma operação fundamental, a efectuar antes do tratamento térmico. Um tecido já fixado termicamente e limpo em descontínuo numa máquina de tingimento terá características qualitativamente inferiores, além de um custo de laboração mais elevado.

Starwash FS EVO está completamente diseñado y construido MCS.

Cada nuevo modelo es probado y expuesto, en INNOVATIVE BLUE ÁREA integrado en la tintorería del grupo MCS.

STARWASH FAST SCOUR EVO has been designed for scouring in continuous with heatsetting, in order to reduce the quantity of oil present in elastic fabrics and to prepare the fabrics to subsequent processings.

Oils to be eliminated are mainly silicones coming from elastomers and minerals used as lubricants in weaving. Such oils, burning at high temperatures during heatsetting, are eliminated unevenly and create areas with different absorptions inside the fabric itself.

Reduce and make these oils even on the surface of the fabrics becomes a fundamental operation to be carried out before heat-setting. Heat-set fabrics, scoured in a discontinuous machine will have inferior qualities, as well as more expensive processing costs.

Starwash FS EVO is entirely engineered and built in MCS.

Each new model is tested and exhibited, in INNOVATIVE BLUE AREA integrated in the MCS Group dyeing plant.



HISTÓRIA DAS LINHAS CONTÍNUAS DE MCS

1974 A MCS inicia a concepção e desenvolvimento de linhas de lavagem.

1983 ITMA - Milano: MCS expõe a primeira gama para lavagem em corda WR

1991 ITMA - Hannover: MCS expõe a primeira gama de lavagens combinadas LAVAPRINT

2011 ITMA - Barcellona: MCS expõe a gama de lavagem de tambor STARWASH

2015 ITMA - Milano: MCS espone la prima gamma di lavaggi in corda compatti MULTIWASH

2019 ITMA - Barcellona: MCS a presenta STARWASH-EVO

2023 ITMA - Milano: MCS a presenta MULTIWASH-M

HISTORY OF CONTINUOUS LINES MCS

1974: MCS begins the design and development of the open-width lines.

1983 ITMA - Milan: MCS exhibits the first rope washing range WR

1991 ITMA - Hannover: MCS exhibits the first combined washing range LAVAPRINT

2011 ITMA - Barcelona: MCS exhibits the drum washing range STARWASH

2015 ITMA - Milan: MCS exhibits the first compact washing range MULTIWASH and STARWASH FAST SCOUR

2019 ITMA - Barcelona: MCS exhibits the STARWASH-EVO

2023 ITMA - Milan: MCS exhibits the first modular washing range MULTIWASH-M

STARWASH FS EVO

OPEN-WIDTH TENSION-LESS SCOURING BOX

STARWASH FS (Escovagem rápida) é a inovadora caixa de limpeza MCS, ideal para fibras sintéticas e naturais também com elevada composição de elastómeros. Modular e compacta permite processar tecidos, quer de malha quer de trama e teia, graças ao sistema patentado, SISTEMA DE TRANSBORDO & BOLHAS.

STARWASH FAST SCOUR EVO (FS EVO) is the innovative scouring box by MCS, ideal for synthetic and natural fibers with high percentage of Lycra. Modular and compact, it allows to process knitted and woven articles as well thanks to patented OVERFLOW & BUBBLE SYSTEM.

Elimination Oil to protect the environment

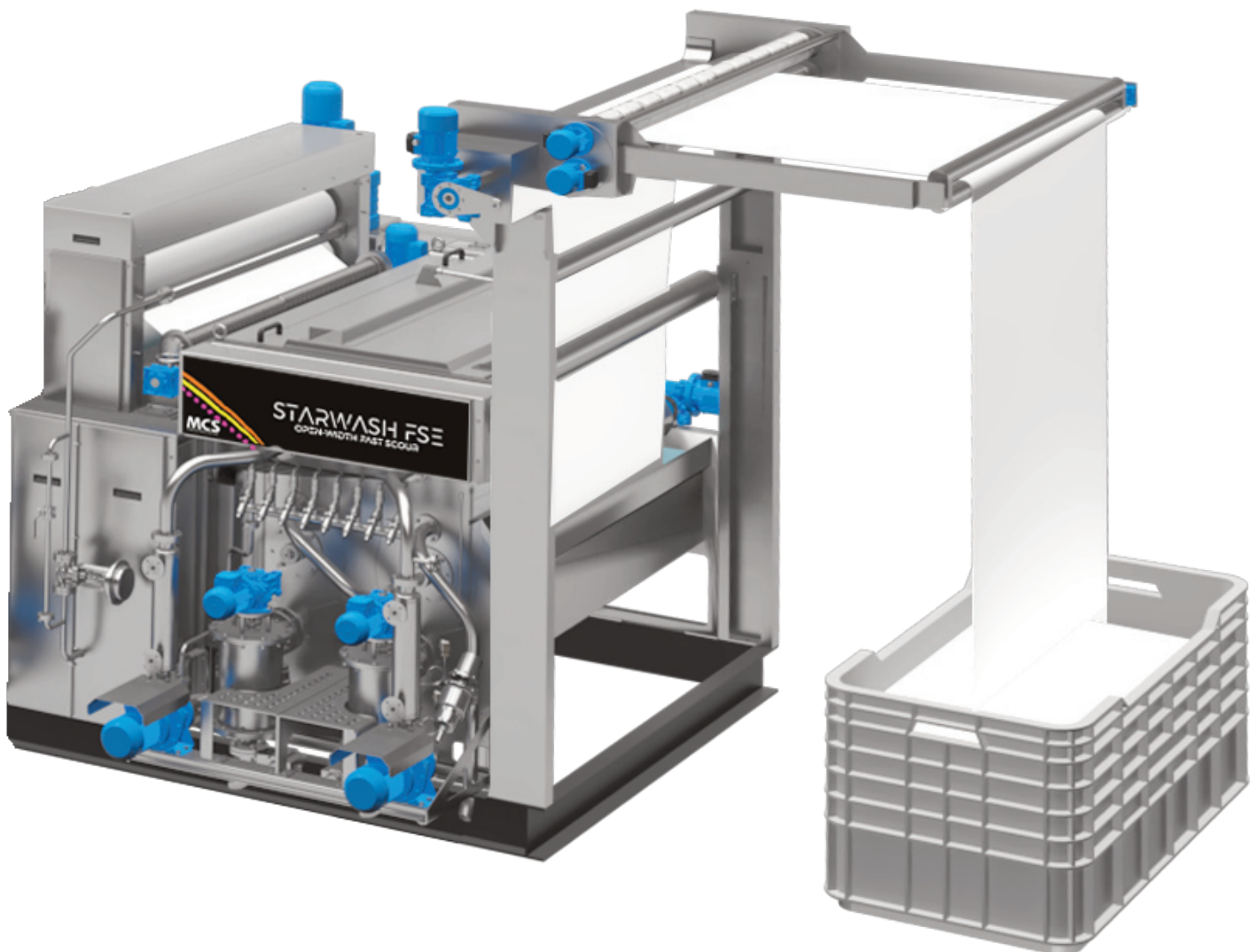

TECHNICAL DATA

O transporte do tecido acontece através de dois tambores motorizados interiores de grandes dimensões, três cilindros de remessa sobre os quais estão montadas células de carregamento e um lenço de espremedura.

A recirculação interna do banho forçado de lavagem e a presença de pulverizadores, permitem ao mesmo tempo um grande impacto de limpeza, uma delicadeza extrema sobre as fibras mais sensíveis e a inteira eliminação dos detergentes utilizados no processo de limpeza. Os óleos residuais são eliminados graças a um filtro especial.

Fabric runs thanks to two big-size driven drums , three transmission rollers on which load-cells are installed, and then a squeezer.

Inner circulation of forced liquor and sprayers guarantee a remarkable washing impact and, at the same time, an extremely delicate action on more sensitive fibres and complete removal of detergents used during scouring process. Removed oils are eliminated by means of a special filter.

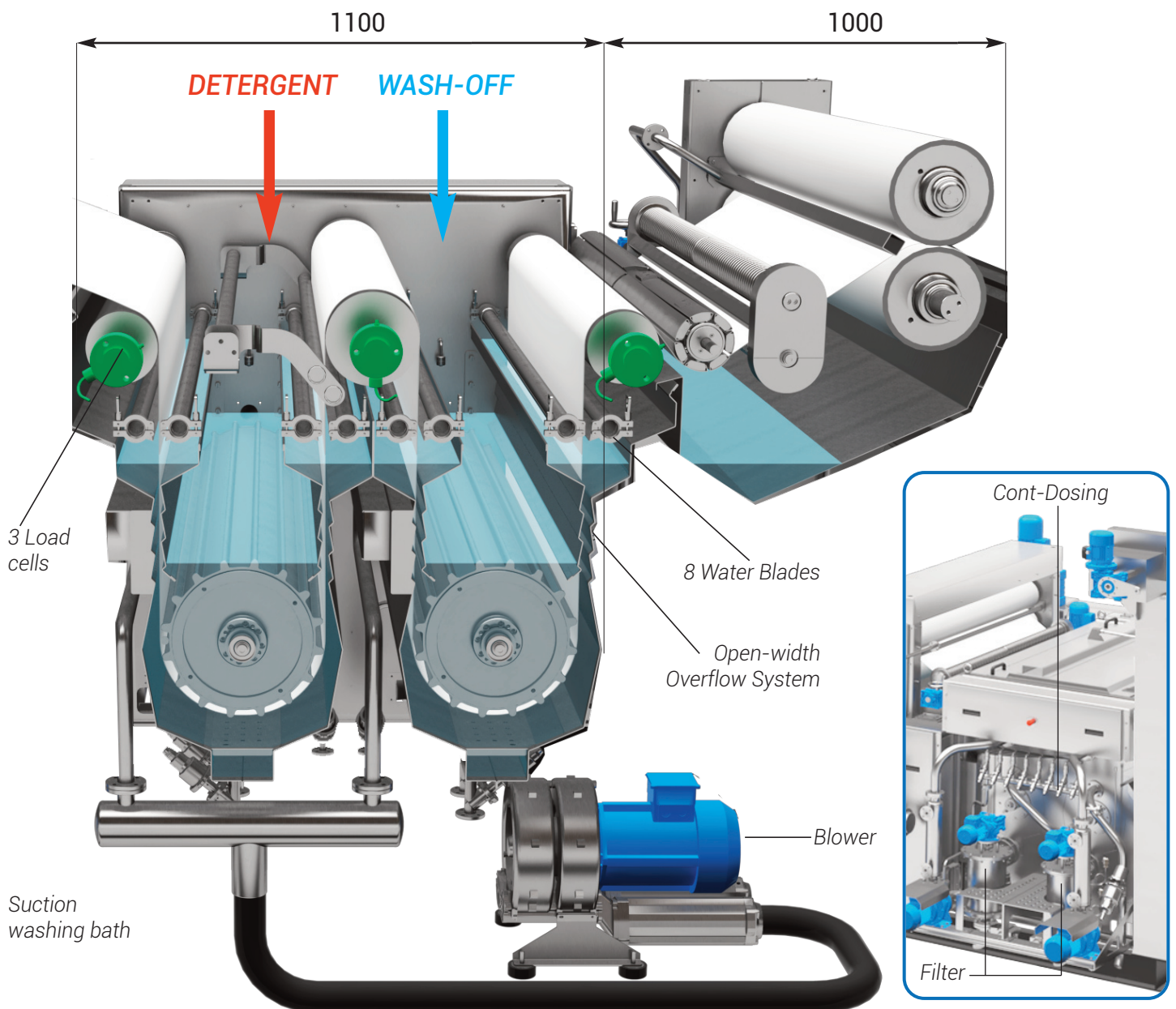

LAYOUT EXAMPLES

SOLUTION 1

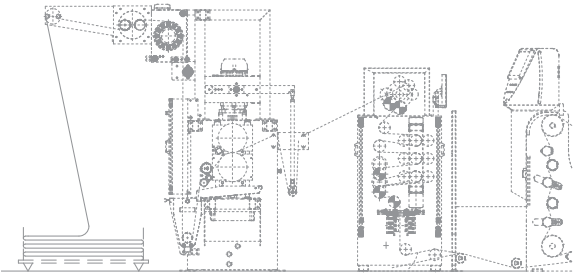

Original Customer Configuration

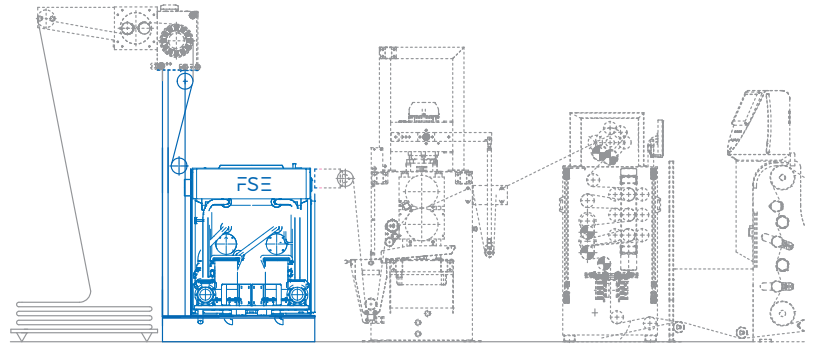

MCS Suggest: Only Starwash FS EVO

SOLUTION 2

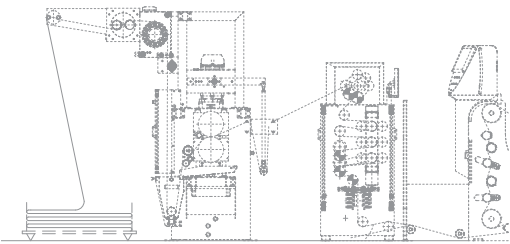

Original Customer Configuration

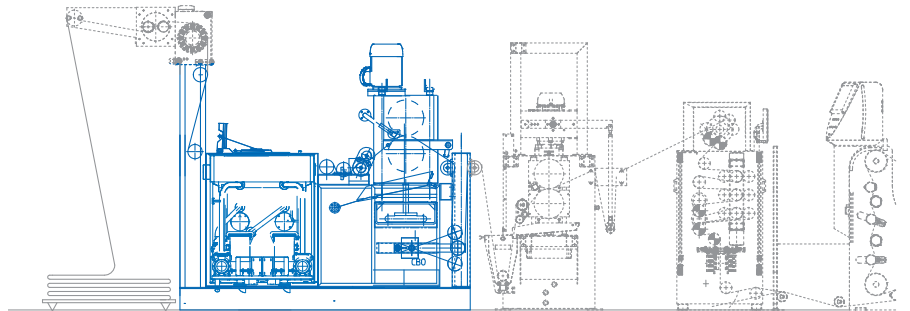

MCS Suggest: Starwash FS EVO + Expanders + 10 tons Squeezer

SOLUTION 3

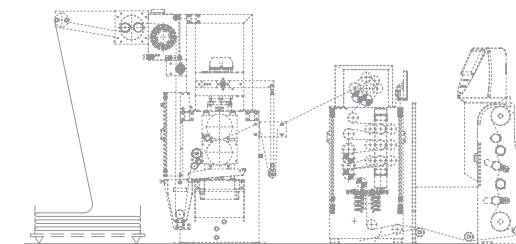

Original Customer Configuration

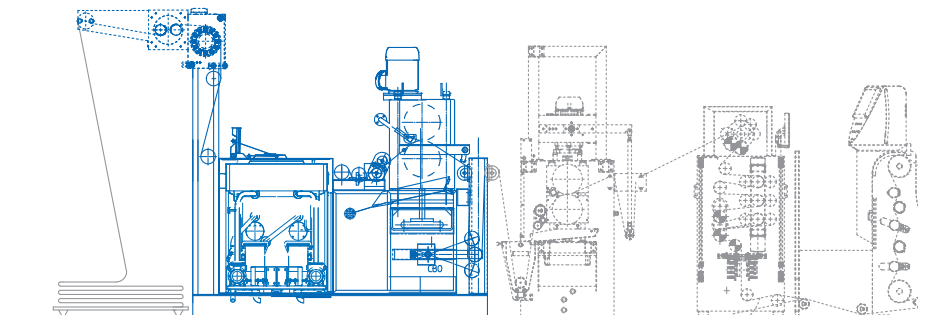

MCS Suggest: Fabric width dogal inlet + Starwash FS EVO + Expanders + 10 tons Squeezer

CTRL-WASH operation panel

CTRL-WASH next gen Windows 10 IOT com tela sensível ao toque capacitiva e novo software de controle TECOP que apresenta uma interface gráfica completamente redesenhada com sinóptico dinâmico em gráficos vetoriais.

CTRL-WASH next gen windows 10 IOT with capacitive touch screen and new automation software TECOP bringing a completely new graphical interface, dynamic synoptic and vectorial graphics.

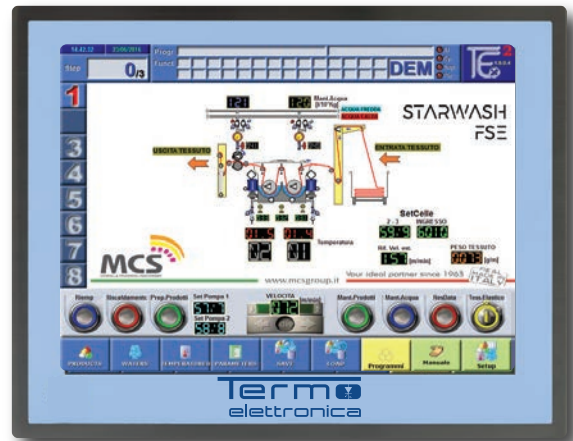

CONT-DOSING Dosing of pure products and water control in a washing line

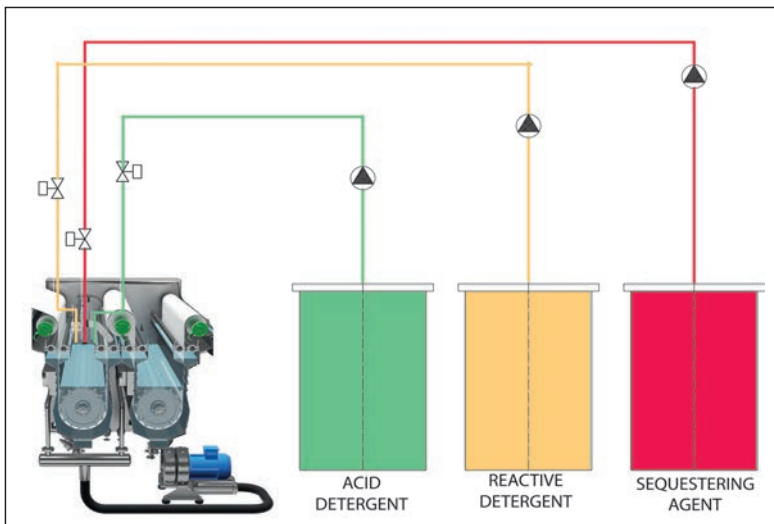

O sistema CONT-DOSING é um sistema gerenciado por um PC em comunicação com um PLC; pode controlar até 8 bombas dosadoras e controlar até 8 entradas de água. As bombas dosadoras utilizadas são de efeito duplo pistão pneumático: a frequência de controle é calculada para evitar mudanças repentinas e na concentração do banho.

The CONT-DOSING system is a system managed by a PC communicating with a PLC which can control up to 8 dosing pumps and 8 water inlets.

Installed dosing pumps are with pneumatic piston at double effect. Pump control frequency values are calculated so as to avoid sudden changes in the concentration of the bath.

TEX-LINE 4.0 Software integrated for washing lines

- ▶ Gestão da parametrização da linha
- ▶ Gestão de planejamento
- ▶ Controle de dados da máquina em tempo real
- ▶ Base de dados de artigos
- ▶ Parametrization Handling
- ▶ Batches Handling
- ▶ Real time machines supervising
- ▶ Fabrics database

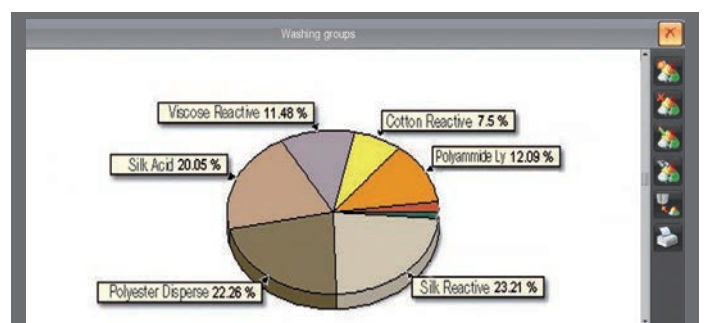

FEEL THE POWER OF WATER

DYEING & FINISHING MACHINERY



MCS

Bergamo | Italy | mcstextile.it



THINK BEFORE YOU PRINT